

Heating with Wood



Heating Systems ◀

Industrial Systems

Refrigeration Systems

Why Wood Heating?

Rising cost of fossil fuels and growing concern for the environment have led to an increasing demand for renewable energy. Modern wood heating is an eco-friendly and economical alternative (or addition) to conventional fossil fuel heating systems.

Did you know?

A number of federal, state and utility incentive programs are available throughout North America. Visit www.dsire.org for a list of U.S. state incentive programs. In Canada, check the Natural Resources Canada website www.nrcan.gc.ca or contact your local Viessmann Sales Representative.

Sustainable

When harvested in conjunction with sustainable forestry, wood is a renewable and environmentally-responsible form of energy and an important part of sustainable resource management.

CO₂-neutral

Burning wood releases as much CO₂ as trees absorb in their lifetime. Heating with wood is therefore CO₂-neutral** and does not contribute to climate change.

Economical

As a local energy source, wood is affordable and independent of wide price fluctuations. In times of volatile energy prices, wood remains stable and highly competitive.

High-tech and reliable

Modern biomass systems are fully-automatic and equipped with high-tech control and safety devices for reliable, efficient and safe operation.

Local and independent

Wood is a local staple and independent of wide price fluctuations. Wood is harvested with minimal energy input and contributes to the regional economy.



**Wood is a "near carbon neutral" fuel to reflect that fact that a small amount of fossil fuel is used to harvest, process and transport the wood. Typically this is less than 1% of the total carbon content.

What You Need to Know

What type of wood can I use?

Viessmann wood heating systems can use a variety of untreated, high-quality wood fuels that vary in heating value, required storage capacity and cost (see right column). What fuel type you choose will largely depend on your storage capacity, system requirements and the availability of the fuel in your area.

As the quality of the fuel impacts the efficiency and life expectancy of your system, it is best to choose a good-quality, untreated wood fuel with a low water content.

How economical is it?

In a biomass system, the fuel cost is an estimated 50% of the total lifecycle cost. Choosing a high-efficiency wood-fired boiler and high-quality, cost-efficient wood fuel thus is key in optimizing the economy of your system. Compared to traditional fossil fuels, the average cost per heat unit of wood fuel is significantly lower in most areas in North America. So while the investment cost of a biomass system may in many cases be higher than a conventional heating system, the fuel cost savings per unit of heat can offset the investment in a relatively short timeframe - making your biomass system as economical or better than a fossil fuel heating system. Plus, with a fuel source that is local and independent, your fuel cost is less volatile than with traditional fuels.

Is it safe?

Absolutely. Today's wood heating systems are as safe and reliable as leading gas/oil heating systems. Equipped with advanced safety and fire protection devices, and a digital control, the entire system is closely monitored and controlled - from the fuel feed right to the heat transfer and venting.

Viessmann wood-fired boilers are built to ASME, Section IV requirements, are CRN registered, and have been tested to CSA/UL Safety Standards (including all safety controls).

Is it clean-burning?

Yes! Modern wood heating systems, when professionally operated and maintained, reach similar emission levels to leading fossil fuel heating systems. Better yet, wood heating is CO₂-neutral. Viessmann wood-fired boilers meet the stringent regulations of the European Clean Air Act.

What applications can it be used for?

Our wood heating systems are ideally suited for commercial and industrial applications, such as schools, hospitals, community heating systems, wood processing plants and more. They are designed to carry either the entire heating load of your system or the baseload, when combined with an oil/gas-fired boiler for peak times.

Our comprehensive product portfolio also allows you to expand your biomass installation into a fully integrated system, complete with Viessmann solar, oil/gas boiler and custom control technology (see page 13).



Pellets
Most compact wood fuel with least storage required. High heating value.



Mixed Woods
Dry Chips Precision sized, uniform, dry chips. Ideal for smaller systems and compatible with Vitoflex RF. Max. water content: 30%."



Woodchips
Shredded, untreated, with or without bark. Large storage required. Max. size: G50. Max. water content: 50%.

One of Germany's largest facilities powered by biomass heating technology. Recreational Pool and Spa. Kempten, Germany.



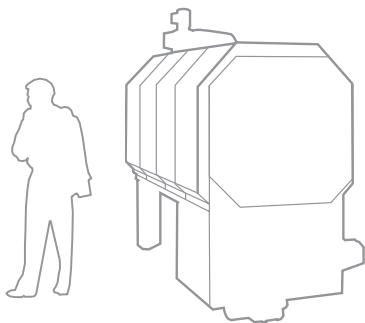

VITOFLEX-RF

Industry-leading rotating combustion wood-fired boiler, 512 to 1843 MBH

For wood fuels with max. water content of 35%

Industry-leading design

With its patented rotating combustion chamber design, the Vitoflex-RF boiler features the industry's most advanced combustion technology. An infeed auger continuously moves the wood fuel onto a moving grate, where gasification of the fuel (under precisely controlled primary air) takes place.

The combustible gases then rise into the rotating combustion chamber, where, through spin impulses of the rotation blower, the gases blend with precisely controlled secondary air, resulting in a complete combustion.

Clean-burning and efficient

Equivalent in quality to modern gas combustion, the advanced combustion process of the Vitoflex-RF also keeps emission levels of CO (<10 ppm), NOx (<75 ppm) and dust particles (<0.06 lb/MMBtu) to a minimum.‡

Plus, unlike oil or gas, wood is a CO₂-neutral, renewable form of energy. Used with our digital, modulating-output control, the Vitoflex-RF boiler achieves an efficiency of 85% †.

Portable boiler enclosure

The Vitoflex-RF can be provided in a portable boiler enclosure for applications where housing for the boiler is not available or onsite construction costs must be kept to a minimum. This pre-packaged solution includes the boiler pre-installed in a specialized shipping container (see page 5) and all peripheral equipment. Customized portable boiler enclosures can be designed and supplied by qualified contractor partners to suit your individual needs.

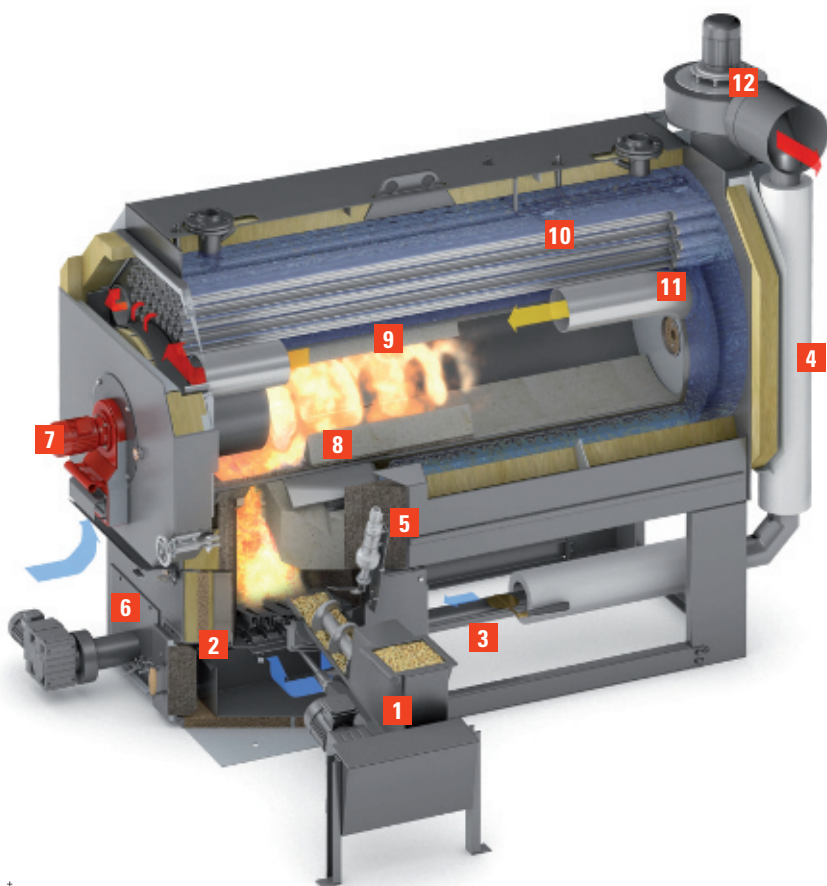

- 1 Infeed auger (with light barrier)
- 2 Moving grate
- 3 Primary air intake
- 4 Flue gas recirculation system
- 5 Igniter
- 6 Deashing system
- 7 Secondary air intake blower
- 8 Rotating combustion system
- 9 Triple-pass heat exchanger
- 10 Safety heat exchanger
- 11 Pneumatic cleaning system
- 12 Flue gas exhaust blower

‡ Tests by TUV Munich

† Efficiency based on the higher heating value of the fuel.



Vitoflex-RF with infeed auger and rotary blower



Portable boiler enclosure
(pellet silo field supplied)



Courtesy of Carrie Bearss – Imedge Photography

Specifications

- Fully-automatic rotating combustion wood-fired boiler
- 5 models from 512 to 1843 MBH
- For dry wood fuels with max. water content of 35%
- Efficiency: 85%†
- Available for 30 or 60 psig max. operating pressure

For technical data, see page 12.

Benefits at a Glance

- High efficiency with advanced combustion technology, triple-pass heat exchanger and modulating output control (turndown ratio 4:1).
- Maximum heat transfer with triple-pass heat exchanger design.
- High efficiency and ultra-low emissions with precisely controlled primary and secondary air.
- Automatic ignition device limits idling and saves fuel.
- Low maintenance with fully-automatic deashing, optional pneumatic cleaning system and flue gas cyclone.
- Advanced safety equipment ensures safe and reliable operation.
- Custom design of your system by our team of experts.
- Available as convenient portable boiler enclosure.

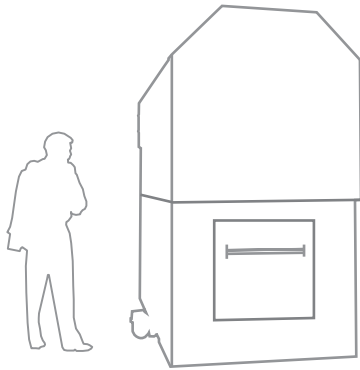

VITOFLEX-UF

State-of-the-art underfeed combustion wood-fired boiler, 1330 to 4268 MBH

For wood fuels with max. water content of 50%

Grate firing at its best

The Vitoflex-UF boiler uses a burner trough with an attached external grate and a moving annealing grate to achieve optimal combustion results. An infeed auger moves the wood fuel into the burner trough where the fuel is pre-dried and gasified under precisely controlled primary air (underfeed combustion). On the external and the moving annealing grate the fuel completely gasifies. Precisely controlled secondary air is injected for full combustion and thermal energy is released into the boiler's triple-pass heat exchanger.

Quality design and construction

The Vitoflex-UF boiler is quality-constructed to handle the toughest of loads. The combustion chamber is lined with compressed firebricks with a high alumina content for added durability. All grate elements are made of durable cast chrome steel to withstand even the highest temperatures. The Vitoflex-UF boiler features a classic triple-pass heat exchanger design for maximum heat transfer and efficiency.

Clean-burning and efficient

Equivalent in quality to modern gas combustion, the advanced combustion process of the Vitoflex-UF keeps emissions of CO and NOx to levels comparable to those of modern fossil fuel heating systems. Plus, unlike oil and gas, wood is a CO₂-neutral, renewable form of energy. Used with our digital, modulating-output control, the Vitoflex-UF boiler achieves an efficiency of 85%†.

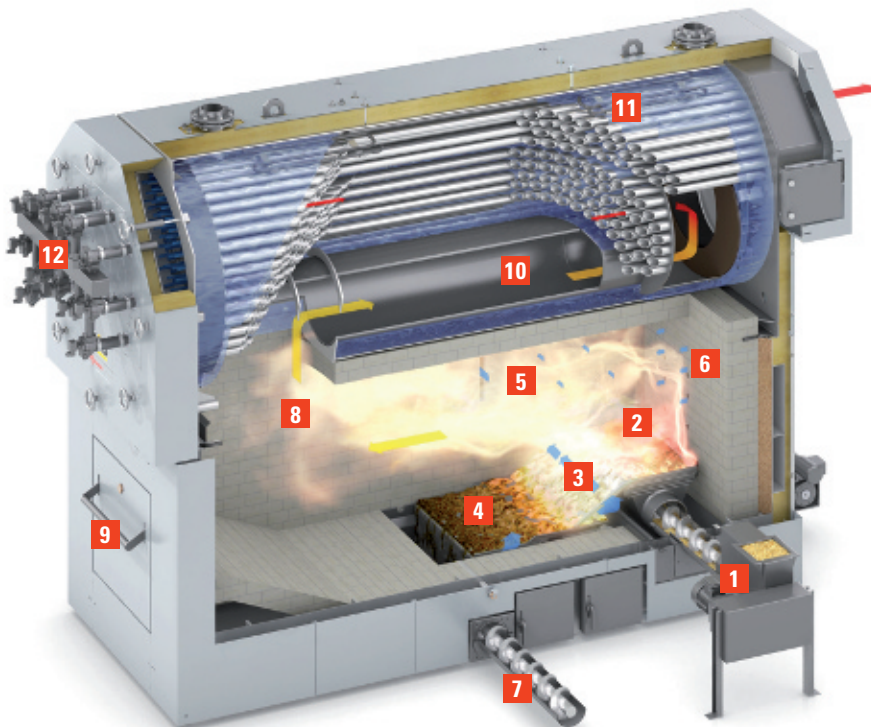

- 1 Infeed auger (with light barrier)
- 2 Burner trough with internal grate
- 3 Sloped grate
- 4 Moving grate
- 5 Secondary air flow
- 6 Igniter
- 7 Deashing system
- 8 High-temperature burnout zone
- 9 Combustion chamber door
- 10 Triple-pass heat exchanger
- 11 Safety heat exchanger
- 12 Pneumatic cleaning system

† Efficiency based on the higher heating value of the fuel.



Vitoflex-UF boiler with pneumatic cleaning system



Firebrick-lined combustion chamber with external grate and moving annealing grate.



Large, air-cooled combustion chamber door with solid double hinge. Creates a wide opening ideal for maintenance.

Specifications

- Fully-automatic underfeed combustion wood-fired boiler
- 5 models from 1330 to 4268 MBH
- For wood fuels with max. water content of 50%
- Efficiency: 85%+
- Available for 30 or 60 psig max. operating pressure

For technical data, see page 12.

Benefits at a Glance

- High efficiency with advanced combustion technology, triple-pass heat exchanger and modulating output control (turndown ratio 4:1).
- Maximum heat transfer with triple-pass heat exchanger.
- High efficiency and ultra-low emissions with precisely controlled primary and secondary air.
- Low maintenance with fully-automatic deashing, optional pneumatic cleaning system and flue gas cyclone.
- Advanced safety equipment ensures safe and reliable operation.
- Maximum system performance with heavy-duty construction and all system components from one source.
- Automatic ignition device limits idling and saves fuel (*optional - only for fuels with less than 40% moisture content*).
- Custom design of your system by our team of experts.

Fully Automatic and Low Maintenance

A complete range of system components from one source ensures reliable and smooth operation of the entire system.



Flue gas cyclone to meet low dust emission requirements.

Automatic deashing system *(optional)*

Clean combustion leaves behind wood minerals in the form of ashes. A moving grate extracts the ashes from the combustion chamber and transfers them into the ash container. Once cooled, the ash removal auger extracts the ashes into a large external ash container.

Pneumatic cleaning system *(optional)*

A clean heat exchanger is key for the longevity and efficiency of a boiler. The pneumatic cleaning system periodically removes ashes from the fire tube heat exchanger with micro blasts of compressed air, extending the boiler's maintenance-free operation period significantly.

Flue gas recirculation system

(standard for Vitoflex-RF, optional for Vitoflex-UF)

Flue gas contains little oxygen (6-8%). When mixed with primary air, it ensures complete gasification of the fuel under air deficiency. This produces a low grate temperature that results in increased boiler efficiency, reduced particle emissions as well as greater grate longevity.

Flue gas cyclone *(optional)*

Minimizes dust emissions by filtering the flue gases through a multi-cyclone array. Comes fully insulated with an exhaust fan mounted on the side or top, and a 64 USG ash container. A 212 USG ash container is optional.

(Only required for fuels with high fine particle content, e.g. waste wood from wood processing plants or woodchips with fine particle content of > 4%.)

Automatic firetube cleaning brush *(service tool)*

Automated, pneumatic, vibrating cleaning brush cuts the cleaning time of boilers by 50%. When inserted from the front and activated, the brush "runs" through the individual tube and back, gently removing ash and dust deposits. Clean fire tubes ensure optimal heat transfer and increased efficiency.



Ash removal auger and external ash container



Pneumatic cleaning system



Flue gas recirculation system

Complete Energy Management

High-tech modulating-output control systems for maximum and safe performance of the heating system.

Modern biomass control systems provide the same control convenience as most standard fossil fuel control technology. Equipped with a modulating-output control and a thermal storage tank, the system supply temperature can be accurately modulated to outdoor weather conditions.

Ecotronic boiler control *(for Vitoflex-RF)*

Digital modulating-output control ensures optimal combustion by precisely controlling the ratio of combustion air, recirculated flue gas and fuel. The control monitors:

- Boiler supply/return temperatures
- Firebed level
- Light barriers of the feed system
- Flue gas temperature
- O₂ content of flue gas (Oxygen sensor)

Pyrocontrol boiler control *(for Vitoflex-UF)*

Fully-programmable modulating-output combustion and system control. The control regulates all variable-speed fans and monitors:

- Boiler supply/return temperatures
- Light barriers of the feed system
- Pressure sensor for reliable negative pressure
- Flue gas temperature
- Combustion chamber sensor (temperature high limit)
- O₂ content of flue gas (Oxygen sensor)

Thermal storage tank

In a biomass system, a thermal storage tank is a key component in achieving maximum control accuracy (ability to adjust system output to actual demand). The thermal storage tank facilitates temperature stratification, effectively reducing cycling of the firing system and accurately matching the system supply temperature to the heat demand. Either three or five buffer tank sensor inputs are provided (depending on the system) Up to 5 sensor inputs are available on all controls for optimal burner modulation according to tank temperature.

Vitocontrol multi-boiler control

Custom control solution for the staging and rotation of two Vitoflex-RF or Vitoflex-UF boilers and the energy management of other integrated energy sources (solar, oil/gas, electric). Controls joint storage and feed system and interfaces with Building Management Systems (BMS).

Remote monitoring system *(optional)*

Off-site monitoring and maintenance of the heating system via web-interface. Allows for the observation and adjustment of various system parameters. Optional LonWorks® and BACnet® interface for local supervision (other interfaces available upon request). Ideal for system monitoring in a public facility or at community/district heating plants.

CSA approved

All biomass control systems are built in-house, and are CSA approved in North America in conjunction with our wood-fired boilers. Plus, benefit from...

- fast installation with all functions in one control
- ease of service and maintenance
- wiring diagrams for each system

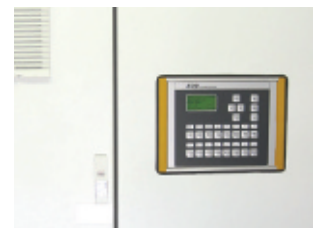

Ecotronic and Pyrocontrol come integrated into a CSA approved electrical panel.



Storage and Feed Systems

Each fuel storage and feed system is unique and designed for a specific application. Our advanced, fully-automatic feed solutions come ready for installation.

All Viessmann wood-fired heating systems come equipped with...

- large-diameter heavy-duty augers
- spur wheel back-geared motors for high torque
- optimized and large-dimension load passages
- certified equipment for effective fire protection

Basement storage with auger extraction

Basement rooms or rooms previously used for oil storage can be transformed into a pellet storage area without extensive remodeling. Pellets can be blown in over large distances and special feeders transport the pellets reliably and with little energy use.

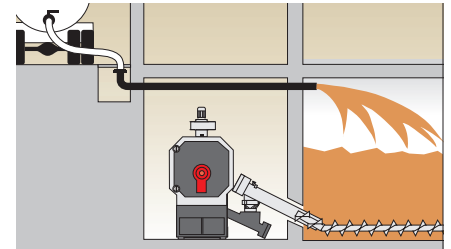

Basement storage with pellet auger

Bunker with rotary sweep extraction

A low-cost option for smaller square or slightly rectangular bunkers. A rotary sweep system moves the fuel onto an extraction auger.

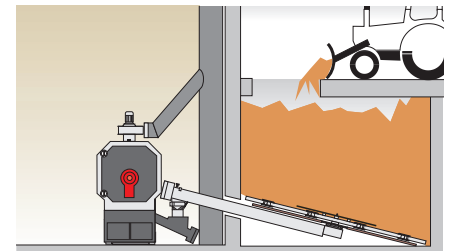

Bunker with rotary sweep extraction

Bunker with walking floor extraction

Ideal for large, rectangular storage bunkers. Sliding hydraulic pushrods move the fuel onto a conveyor auger. Allows for fast filling of large amounts of fuel.

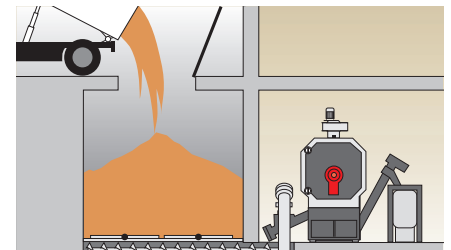

Bunker with walking floor

Silo funnel extraction

A pendulum system in the funnel extracts fuel from the silo. Fail-safe due to automatic reverse gearing.

Walking floor installation



Safe and Reliable Operation

Viessmann wood-fired boilers are built to meet the most stringent safety requirements. High-tech, state-of-the-art safety equipment ensures a safe and reliable operation of your system at all times.

Backflash safeguard

A water-filled metering container attached to the infeed auger and controlled by an optical sensor. Prevents sparks from entering the fuel storage area. The backflash safeguard is a CSA safety requirement.

Burnback preventer

A sensor located in the fuel infeed pipe detects any danger of burnback and quickly counteracts by increasing the feed to the boiler.

Burnback safeguard

A spring-loaded horizontally-acting slide valve interrupts the fuel line in case of power failure or danger of burnback.

If the fuel storage room is under negative pressure a rotary valve is used instead of the slide valve for the same function. The rotary valve prevents unwanted air leaks from reaching the combustion process.

Automatic fire-extinguishing system

A fire extinguishing water tank (25 ltr/6.6 USG) with flow switch will empty and prevent burnback in case of malfunction. If there is a shortage of water, the system will switch off automatically.

Safety heat exchanger

A safety heat exchanger built into the boiler connects to city water and prevents the boiler from overheating in case of a power outage. A non-electric, thermally activated valve is triggered at a fixed boiler temperature and cools the boiler water via indirect heat transfer through the heat exchanger.

Additional safety devices

In addition to the safety equipment listed, Viessmann wood-fired boilers come with the standard safety devices required by the Safety Standards.

- Fixed temperature high limit
- ASME pressure relief valve
- Low water cut-off (LWCO)
- Pressure and temperature gages

The Vitoflex-RF and Vitoflex-UF boilers are built to ASME, Section IV requirements and 30 or 60 psig max. operating pressure. They have been tested and approved to applicable CSA/UL Safety Standards. Pressure vessels for Canada are registered in each province with a Canadian Registration Number (CRN).



Technical Specifications

Vitoflex-RF Rotating Combustion Boiler

For wood fuels with water content < 35%



Model		KRT-150	KRT-220	KRT-300	KRT-400	KRT-540
Output	MBH	512	751	1024	1365	1843
	kW	150	220	300	400	540
Efficiency		85% †				
Max. Operating Pressure		30 or 60 psig				
Dimensions (inches)	Height	70	80	80	90	92
	Length	92	97	97	110	120
	Width	40	52	52	62	62

† Based on the higher heating value of the fuel.

Vitoflex-UF Underfeed Combustion Boiler

For wood fuels with water content < 50%



Model		KPT-390	KPT-530	KPT-720	KPT-950	KPT-1250
Output	MBH	1330	1809	2457	3242	4268
	kW	390	530	720	950	1250
Efficiency		85% †				
Max. Operating Pressure		30 or 60 psig				
Dimensions (inches)	Height	94	100	112	120	130
	Length	129	150	153	150	170
	Width	49	50	55	64	64

† Based on the higher heating value of the fuel.



The Perfect Match for Your System

With Viessmann system technology and services you can easily expand your biomass system and reap the added benefits from a fully integrated renewable energy system.

Unique product mix

With our complete line of commercial high-efficiency fossil fuel boilers, solar thermal systems, advanced biomass heating and custom control technology, you are uniquely positioned to meet the requirements of the most complex energy projects. Whether as a fully integrated system or single-energy application, our products are designed to integrate perfectly and to generate maximum energy savings and system performance for your application.

Expert design services

Whether you are an engineering consultant, an energy service company or design build contractor, our dedicated in-house biomass project team is there to assist with your project every step of the way. From the custom design of your integrated multi-energy project to incorporating your control strategy into our commercial hydronic system, tap into our team's extensive product and design knowledge to get the best possible results from your system.

Performance solar systems

Our high-performance flat plate and vacuum tube solar systems are ideal to heat domestic hot water and to provide space heating backup for your biomass system.

By integrating solar, you can offset your domestic hot water heating cost by as much as 65% (depending on size of solar system) and further reduce your environmental footprint.

Powerful DHW tanks

Our Vitocell line of indirect-fired domestic hot water (DHW) storage tanks offers high-quality construction and fast recovery rates for an abundant, reliable hot water supply at all times. For applications with a high hot water load, combine our vertical or horizontal DHW tanks into tank batteries. Integrating indirect domestic hot water heating in your biomass system can save as much as 50% in operating cost compared to conventional direct-fired hot water production.

Proven heating boilers

In an integrated renewable energy system, biomass heating is often coupled with conventional oil/gas-fired boilers to handle peak loads or to provide backup to the biomass boiler. Depending on the type and temperature requirements of your system, Viessmann offers highly-efficient wall-mount and floor-standing condensing boilers or sectional cast iron boilers to integrate with your biomass system.

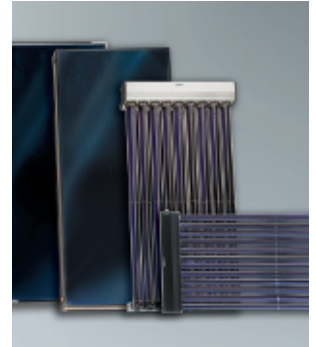

- 1** Viessmann custom control panel
- 2** Solar thermal system
- 3** Wood heating system
- 4** Condensing boiler(s)
- 5** Non-condensing boiler
- 6** Thermal storage tank
- 7** System distribution

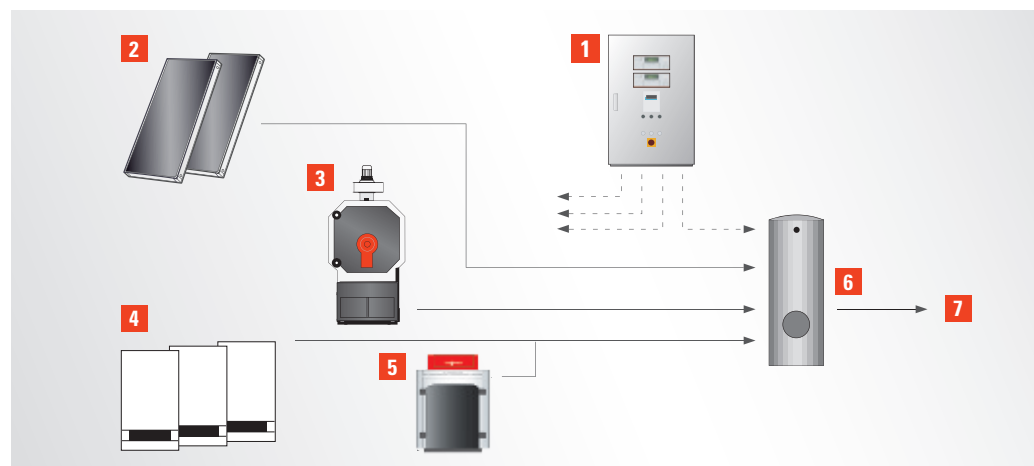

Biomass Systems at Work

More than 1500 installations worldwide are powered by Viessmann biomass technology.

Viessmann biomass systems

Viessmann has installed large-scale, wood-fired heating systems, and has earned recognition for innovative and environmentally-friendly product advancements.

Design and commissioning services

Each Viessmann installation begins with a system design from our in-house team of experts. By examining the unique requirements and conditions of your project, we propose a customized system solution – from a stand-alone wood-fired boiler to a fully integrated system, including fossil fuel heating and solar systems.

Comprehensive system solutions and services from one manufacturer!



Fink Enderby District Energy System†
Enderby, BC



The Mount Community
Esopus, NY



Camrose County Office
Camrose, AB



Bluenose Academy
Lunenburg, NS



Cité Verte, Green Community
Québec City, QC



University of Northern BC†
Prince George, BC



Viessmann Production Plant
Wolfurt, Austria



Sealaska Plaza Building
Juneau, AK



College of the Atlantic
Bar Harbor, ME



Our Lady of Mercy School
Bancroft, ON



Nazko Valley School
Quesnel, BC



Academic Teaching Hospital
Alzey, Germany

† Courtesy of Carrie Bearss – Imedge Photography ‡ Courtesy of the University of Northern British Columbia

Viessmann - The Company

Viessmann - climate of innovation

The Viessmann brand promise concisely expresses all that we hope to achieve. It is our key brand message and, together with our brand label, an identifying feature throughout the world.

"Climate of innovation" is a promise on three levels: a commitment to a culture of innovation, a promise of high product utilization and an obligation to protect the environment.

Comprehensive range of products and services for all fuel types

Viessmann is one of the leading international manufacturers of heating systems and, with its comprehensive range of products and services, offers individual solutions of efficient systems for all applications and fuel types. As an environmental pioneer, the company has been supplying particularly efficient and clean heating systems for decades.

Acting in a sustainable manner

For Viessmann, to take responsibility, means a commitment to act in a sustainable way. This means bringing ecology, economy and social responsibility into harmony with each other, ensuring that current needs are satisfied without limiting the basis for life for the generations to come.

Efficiency program

With our efficiency program, Viessmann shows that the political goals set for 2020 with regard to climate and energy can already be achieved today with commercially available technology.

This project demonstrates:

- Environmental protection
- Efficiency with resources
- Securing manufacturing sites for the future

As a result, fossil fuels have been cut by 40 percent and CO₂ emissions reduced by a third.



Deutscher Nachhaltigkeitspreis
Deutschlands nachhaltigste Marke 2013

Viessmann won the German Sustainability Award 2013 for its commitment to climate protection and efficient use of resources.



For the particularly efficient utilization of energy through the innovative heat recovery center at the company's main site in Allendorf/Eder, Viessmann was rewarded with the Energy Efficiency Award 2010.

Company Details

- Established in: 1917
- Employees: 11,600
- Group turnover: \$2.5 billion USD
- Export share: 56 percent
- 22 production divisions in 11 countries
- 74 countries with subsidiaries and representations
- 120 sales offices worldwide

Performance spectrum

- Condensing technology for oil and gas
- Solar thermal systems
- Heat pumps
- Wood combustion systems
- CHP modules
- Biogas plants
- Services



climate of innovation®

Viessmann Manufacturing Company Inc.

Viessmann Manufacturing Company (U.S.) Inc.
Warwick, RI U.S.A.
1-800-288-0667
www.viessmann-us.com

Other Viessmann Group renewable energy technology facilities in North America

BIOFerm™ Energy Systems

440 Science Dr, Ste 300
Madison, WI USA 53711
Tel. (608) 467-5523
Fax (608) 233-7085
www.biofermenergy.com

BIOFerm™ Energy Systems is a leading provider of turnkey anaerobic digestion and gas upgrading facilities in North America, with over 450 digester installations and 900 pressure swing adsorption installations through the Viessmann Group. To sustainably and economically repurpose organic waste - to fuel, electricity, heat, organic products - BIOFerm™ offers the complete suite of Viessmann biogas technologies to North America: dry fermentation, wet fermentation, hybrid, and small-scale digesters, as well as pressure swing adsorption biogas upgrading facilities.

